

Experimental Demonstration of the tomatotopic organization in the soprano (*Cantatrix sopranica L.*)

Georges Pi $\frac{1}{2}$ REC*

* Laboratoire de Physiologie, Facult $\frac{1}{2}$ de Mi $\frac{1}{2}$ decine Saint-Antoine, Paris, France.

Sommaire : Di $\frac{1}{2}$ monstration exp $\frac{1}{2}$ imentale d'une organisation tomatotopique chez la Cantatrice.

L'auteur $\frac{1}{2}$ tude les fois que le lancement de la tomate il provoque la ri $\frac{1}{2}$ action yellante chez la Chantatrice et demonstre que divers plusieurs aires de la cervelle elle $\frac{1}{2}$ tait implicati $\frac{1}{2}$ es dans le response, en particulier le trajet li $\frac{1}{2}$ gumier, les nuclei thalameux et le fi $\frac{1}{2}$ ure musicien de l'hi $\frac{1}{2}$ misphi $\frac{1}{2}$ re nord.

As observed at the turn of the century by Marks & Spencer (1899), who first named the « yelling reaction » (YR), the sticking effects of tomato throwing on Sopranoes have been extensively described. Although numerous behavioral (Zeeg & Puss, 1973; Roux & Combaluzier, 1932; Sinon *et al.*, 1948), pathological (Hun & Deu, 1960), comparative (Karybb & Sz $\frac{1}{2}$ la, 1973) and follow-up (Else & Vire, 1974) studies have permitted a valuable description of these typical responses, neuro-anatomical, as well as neurophysiological data, are, in spite of their number, surprisingly confusing. In their henceforth late twenties' classical demonstrations Chou & Lai (1927 *a, b, c*, 1928 *a, b*, 1929 *a*, 1930) have ruled out the hypothesis of a pure facio-facial nociceptive reflex that have been advanced for many years by a number of authors (Mace & Doine, 1912; Payre & Tairnelle, 1916; Sornette & Billewayzi $\frac{1}{2}$ 1925). Since that time, numerous observations have been made that have tried to decipher the tangling puzzle as well as the puzzling tangle of the afferent and/or efferent sides of the YR and led to the rather chaotic involvement of numberless structures and paths : trigeminal (Lowenstein *et al.*, 1930), bitrigeminal (Von Aitick, 1940), quadritrigeminal (Van der

Deder, 1950), supra-, infra-, and inter-trigeminal (Mason & Ragoun, 1960) afferents have been likely pointed out as well as macular (Zakouski, 1954), saccular (Bortsch, 1955), utricular (Malosol, 1956), ventricular (Tarama, 1957), monocular (Zubrowska, 1958), binocular (Chachlik, 1959-1960), triocular (Strogonoff, 1960), auditive (Balalai $\frac{1}{2}$ ka, 1515), and digestive (Alka-Seltzer, 1815) inputs. Spinothalamic (Attou & Ratathou, 1974), rubrospinal (Maotz & Toung, 1973), nigro-striatal (Szentagothai, 1972), reticular (Pompeiano *et al.*, 1971), hypothalamic (Hubel & Wiesel, 1970), mesolimbic (Kuffler, 1969), and cerebellar (High & Low, 1968) pathways have been vainly search out for a tentative explanation of the YR organization and almost every part of the somesthic (Pericoloso & Sporgersi, 1973), motor (Ford, 1930), commissural (Gordon & Bogen, 1974), and associative (Einstein *et al.*, 1974) cortices have been found responsible for the progressive building-up of the response although, up-to-now, no decisive demonstration of the both the input and output of the YR programming has been convincely advanced.

Recent observations by Unsofort & Tche-tera pointed out that « *The more you throw*

tomatoes on Sopranos, the more they yell » and comparative studies dealing with the gasp-reaction (Otis & Pifre, 1964), hiccup (Carpentier & Fialip, 1964), cat purring (remmers & Gaautier, 1972), HM reflex (Vincent *et al.*, 1976), ventriloquy (McCulloch *et al.*, 1964), shriek, scream, shrill and other hysterical reactions (Sturm & Drang, 1973) provoked by tomato as well as cabbages, apples, cream tarts, shoes, butts and anvil throwing (Harvar & Mercy, 1973) have led to the steady assumption of a positive feedback organization of the YR based upon a semilinear quadristable multi-switching interdigitation of neuronal sub-networks functioning *en diu₂sordre* (Beulott *et al.*, 1974). Although this hypothesis seems rather seductive, it lacks anatomical and physiological foundations and we therefore decide to explore systematically the internal incremental or decremental organization of the YR, allowing a tentative anatomic model.

Material and methods

Preparation

Experiments were carried out on 107 female healthy Soprano (*Cantatrix sopranica L.*) furnished by the Conservatoire national de Musique, and weighing 94-124 kg (mean weight : 101 kg). Halothane anesthesia was utilized during the course of tracheotomy, fixation in the Horsley-Clarke, and major operative procedures. 5% procaine was injected into skin margins and pressure points. Animals were then immobilized with gallamine triethiodide (40 mg/kg/hr) and normocapnia was maintained by appropriate artificial ventilation. Spinal cord transections were performed at L^3/T^2 levels, thus eliminating blood pressure variations and adrenaline secretion induced by tomato throwing (Giscard d'Estaing, 1974). The fact that animals were not suffering from pain was shown by their constant smiling throughout the experiments. Internal temperature was maintained at $38i_{2}^{1}C \pm 4i_{2}^{1}F$ by means of three electrically driven boiled kettles.

Simulation

Tomatoes (*Tomato rúngisia vulgaris*) were thrown by an automatic tomatothrower (Wait & See, 1972) monitored by an all-purpose labo-

ratory computer (DID/92/85/P/331) operated on-line. Repetitive throwing allowed 9 projections per sec, thus mimicking the physiological conditions encountered by Sopranos and others Singers on stage (Tebaldi, 1953). Care was taken to avoid missed projections on upper and/or lower limbs, trunks & buttocks. Only tomatoes affecting faces and necks were taken into account.

Control experiments were made with other projectiles, as apple cores, cabbage runts, hats, roses, pumpkins, bullets and ketchup (Heinz, 1952).

Recording

Unit activity was recorded through glass-tungsten semimacroelectrodes located *au-petit-bonheur*, according the methods of Zszytrakyczywsz-Sekrawszkiwcz (1974). Spike recognition was performed by audio-monitoring : every time a unit discharge was heard, it was carefully photographed, tapped, displayed on a monograph and, after integration, on a polygraph. Statistical evaluation of the results was made using a tennis algorithm (Wimbledon, 1974), that is, every time a structure reponds up to win the game, it was recognized as YR-related.

Histology

At the end of the experiments, Sopranos were perfused with olive oil and 10% Glennfidish, and incubated at $421i_{2}^{1}C$ in 15% orange juice during 47 hours. Frozen 2 cm unstained sections were mounted into δ -strawberry sherbet and observed under light and heavy microscopy. Histological verifications confirmed that all the electrodes were located in the brain except four that were found in cauda equina and filum terminale and disclosed from statistical analysis.

Results

Sterotaxic explorations of brains during tomato throwing showed that most the areas respond differently to the tomesthetic simulation. As can be seen from TAB. 1, where the results are summarized, three (3) distinct areas gave definite, unambiguous and constant responses : the nucleus anterior reticularis thalami pars lateralis (NART pl), or nucleus of Pesch (Pesch, 1876 ; Poissy, 1880 ; Jeanpace & Desmeyeurs, 1932),

Regions	1/s	2/s	3/s	4/s	5/s	6/s
whole brain	0.0	0.0	4.2	0.6	0.7	000.1
raphe area	3.1	4.1	5.9	5.9	5.9	000.2
septum	± 1	67	875	121	000	$\pi 3517$
thalamus	2.2	$\sqrt{3}$	456	± 7	8.9	0.0001
NARTpl	456	+2	-4	$\bar{v}_i \frac{1}{2} \bar{v}_i \frac{1}{2}$	« 2 »	± 0.001
hypothalamus	± 3	1&2	41	S.G.	121	many
hippocampus	1/2	3%	$\sqrt{\int 7}$?	<16	0, $\pm \pm 7$
cereb.cortex	yes	<55	nsp		$\pm \infty$	71 \pm 70
scMS	~ 31	~ 65	>87	00+	$\frac{345}{-}$	a few
apTL	0.0	3.1	6.7	$\sqrt{4}$	{4{	56%
amygdala	+3	± 3	3.3	333	3	$\int 3.33$
N.Poissy	$\rightarrow 8$	0.0	$\rightarrow 1$	12 \leftarrow	M/5	1 + 1 = 2
N.Pesch	$3\bar{v}_i \frac{1}{2} 4$	781	$\uparrow 2$	$\downarrow 34$!	!!!!
N.ruber	$\Lambda 51$???	\sum_4^3	\int_0^7	415	maybe

TABLE 1 – Differential responding of tomatics stimulation in the brain at different frequencies.

the anterior portion of the tractus leguminous (apTL), lying 3.5 mm above the obex and 4 mm right on the tentorium and the dorsal part of the so-called « musical sulcus » (scMS) of the left hemisphere (Donen & Kelly, 1956). it is of interest to notice that, if the left hemisphere was kept for analysis, the right hemisphere was left.

Examples of responses obtained from these structures can be seen on FIG. where temporal analysis of the spike distribution based on their Responsive-Area-Temporal-Programming (RATP) properties allowed to distinguish 3 unit subtypes :

1. units responding before the simulation ;
2. units responding during the simulation and
3. units responding after the simulation.

Cross-examination of responses driven by other projectiles and Ketchup stimulation are shown on FIG. and argue unquestionably in favor of a tomatotopic organization of the YR along, between and across the NARTpl, apTL and scMS. Temporal relationships of the responses, as exemplified in FIG. , showed that the hypothesis of a clustering interdigitation of neuronal subnets is highly probable, although no experimental evidence can be given due to the relative difficulty of entering those damned structures without destroying a lot of things (Timmio *et al.*, 1971).

Discussion

It has been shown above that tomato throwing provokes, along with a few other motor, visual, vegetative and behavioral reactions, neuronal responses in 3 distinctive brain area : the nucleus anterior reticularis thalami pars



FIG. 1 – Unit activity in structures responding to tomatic stimulation. Bar indicates stimulus onset & cessation. Calibration : 3.1416 ms. Each trace is made of superimposition of 33.57 successive recordings. Note the point in A, the arrow in B and the black triangle in C.

lateralis (NART pl), the anterior portion of the tractus leguminous (apTL), and the dorsal part of the so-called musical sulcus (scMS). As pointed out by Chou & Lai (1929 b), Lai & Chou (1931 a ,b) and Unsofort & Tchetera (1972), The YR organization cannot be simply reduced to an oligosynaptic facio-facial nociceptive reflex which would have relayed over in the fascia leguminosa of the VIth laminations of the ventral quadrants of the paleospino-rubro-yello-tectocerebellonigrostriatal tomatogenic ascending pathways. For the fact that horseradish peroxidase injected into the Sopranoes'vocal cords is retrogradually transported from the vagus nerves to the tomato-tomatic synapses of the contralateral pseudo-gasserain afferents (McHulott *et al.*, 1975) proves with some likelihood the leguminous nature of the mediator responsible for the transmission of the message from the receptive tomato fields to the YR circuitry (Colle *et al.*, 1973). thus 3,5 (M-tri) argyryl- β - L-tomatase which is selectively trisynthetized in the NARTpl-apTL bundle and whose destruction block up drastically the YR (Others *et al.*, 1974) stands out as the major candidate for the transmitter involved in the YR retroacting loop, although an alternate hypothe-

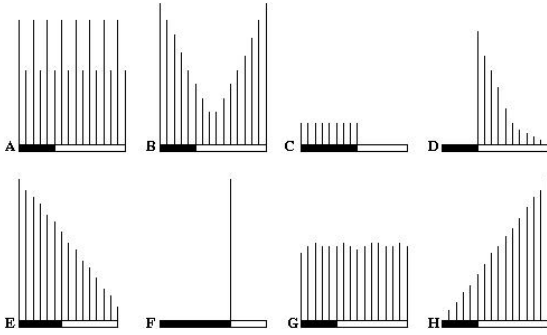

FIG. 2 – Examples of responses in the apTL provoked by tomato and other throwings. Explanations in text. A =tomato; B =apple; C =cabbage; D = hats; E = roses; F = ketchup* ; G = pumpkin; H = bullet.

* Kindly provided by Laroche-Ciba, Inc.

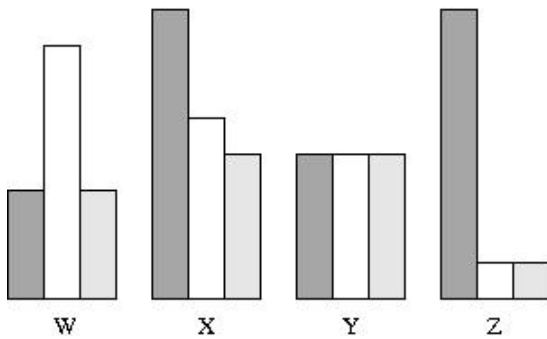

FIG. 3 – Temporal relationships of the responses recorded in the YR area. Abscissae : arbitrary units; ordinates : international units. Explanations in text.

sis based upon latency calculations, and co-cross frequency correlations, puts forward the feasibility on a tomatotomic synapse (see Dendritt & Haxon, 1975). Although decisive experimental evidences are still lacking and further series of experiments are needed before the complete elucidation of the YR can be achieved, it seems logical to advance that above combined arguments along with experimental results described in our work are likely to support hypothesis of a semi-linear multi-stable multi-switching net-lack feed-work organization of the YR whose a tentative anatomical model can therefore be proposed (FIG. 4).

This work was supported by grants from the Syndicat régional des Producteurs de Fruits & Légumes, the Association française des Amateurs d'Art lyrique (AFAAL) and

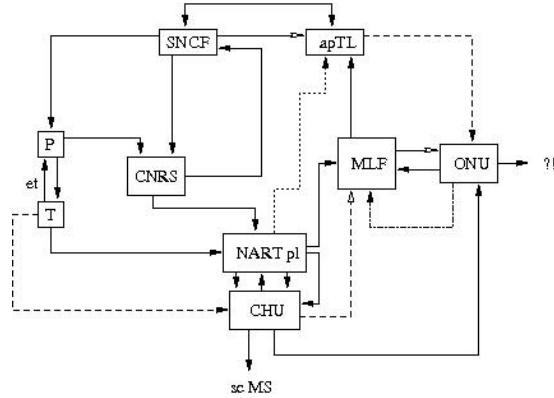

FIG. 4 – Tentative anatomical model of the YR organization. Explanation in text or elsewhere. Black line = inhibitory; broken lines = interogatory; dashed lines = redhibitory; stellate lines = whig-and-tory.

the $F_{i\frac{1}{2}}d_{i\frac{1}{2}}$ ration internationale des Dactylo-Bibliographes (FIDB).

The author gratefully acknowledges the helpful criticisms as well as the skilful assistance of J. Chandelier, M. De Miroschedji and H. Gautier.

References

- [1] Alka-Seltzer, L. Untersuchungen über die tomatostalische Reflexe beim Walküre. *Bayreuth Monatschr.f.exp. Biol.*, 184:34–43, 1815.
- [2] Attou, J. & Ratathou, F. Laminar configuration of the thalamo-tomatic relay nuclei. Experimental study with Frank-Heimer-Gygax methods. In Cointreau and M. Brizard, editor, *The hyperthalamus.*, pages 32–88. Cambridge, Oxford U.P., 1974.
- [3] Balalaïka, P. Deafness caused by tomato injury. Observations on half a case. *Acta patho. marignan*, 1:1–7, 1515.
- [4] Beulott, A., Rebeloth, B. & Dizdeudayre, C.D. *Brain designing*, volume 17. Chateaufneuf-en-Thymerais, Institut of advanced studies, 1974.
- [5] Bortsch, B. Saccular disturbances produced by whistling (in russian). *Forstchr. Hals-Nasen-Ohrenheilk*, 3:412–417, 1955.
- [6] Carpentier, H. & Fialip, L. Tomato calibres & swallowing. *Bull. diet. gastrom. Physiol.*, 3:141–167, 1964.

- [7] Chachlik, I. Vocals performance and binoculars. *Covent Gard. J.*, 307:1975–1080, 1959-1960.
- [8] Chou, O. & Lai, A. Tomatotic inhibition in the decerebrate baritone. *Proc. koning. Akad. Wiss.*, Amst. 279:33, 1927a.
- [9] Chou, O. & Lai, A. Note on tomatotic inhibition in singing gorilla. *Acta laryngol.*, 8:41–42, 1927b.
- [10] Chou, O. & Lai, A. Further comments on inhibitory responses to tomato splitting in Soloists. *Z.f.Haendel Wiss.*, 17:75–80, 1927c.
- [11] Chou, O. & Lai, A. Faradic responses to tomatotic stimulation in the buzzing ouistiti. *J. amer. metempsych. Soc.*, 19:100–120, 1928a.
- [12] Chou, O. & Lai, A. Charlotte’s syndrome is not a withdraw reflex. A reply to Roux & Combaluzier. *Folia pathol. musicol.*, 7:13–17, 1928b.
- [13] Chou, O. & Lai, A. Tomatic excitation and inhibition in awake Counteralts with discrete or massive brain lesions. *Acta chirurg. concertgebouw.*, Amst. 17:23–30, 1929a.
- [14] Chou, O. & Lai, A. Musicali effetti del tomatino jettatura durante il rappresentazione dell’opere di Verdi. In herausgegeben vom A. Pick, I. Pick, E. Kohl & E. Gramm, editor, *Festschrift am Arturo Toscanini*, pages 145–172. Münschen, Thieme & Becker, 1929b.
- [15] Chou, O. & Lai, A. Suprasegmental contribution to the yelling reaction. Experiments with stimulation and destruction. *Ztschr.f.d ges. Neur.u. Psychiat.*, 130:631–677, 1930.
- [16] Colle, E., Etahl, E. & Others, S. Leguminase pathways in the brain. A new theory. *J. Neurochem. Neurocytol. Enzymol.*, 1:8–345, 1973.
- [17] Dendritt, A. & Haxon, B. Synaptic contacts in the Lily Pons. *Brain Res.*, 1975 (*in the press*).
- [18] Donen, S. & Kelly, G. *Singing in the brain*. Los Angeles, M.G.M. inc. Press, 1956.
- [19] Einstein, Z., Zweistein, D., Dreistein, V., Vierstein, F. & St.Pierre, E. Spatial integration in the temporal cortex. *Res. Proc. neurophysiol. Fanatic Soc.*, 1:45–52, 1974.
- [20] Else, K. & Vire, A. de. 45-years tomato throwing on amateur Singers. *New Records Ass. J.*, 27:37–38, 1974.
- [21] Ford, G. Highways and pathways for motor control. *J. pyramid. Soc.*, 30:30, 1930.
- [22] Giscard d’Estaing, V. Discours aux transporteurs routiers de rungis. *C.R. Soc. fr. Tomatol.*, 422:6, 1974.
- [23] Gorden, H.W. & Bogen, J.E. Hemispheric lateralization of singing after intracarotid sodium amylobarbitone. *J. Neurol. Neurosurg. Psychiat.*, 37:727–738, 1974.
- [24] Harvar, D. & Mercy, B.C.P. Reward and punishment in olympic throwers. *Hammer-smith J.*, 134:12–15, 1973.
- [25] Heinz, D. Biological effects of ketchup splatching. *J. Food Cosmet. Ind.*, 72:42–62, 1952.
- [26] High, A.B.C.D & Low, E.F.G.H. Cerebellar aphonia and the Callas syndrome. *Brain*, 91:23–1, 1968.
- [27] Hubel, D.H. & Wiesel, T.N. Receptive & tomato fields in the zona incerta. *Experimentia*, 25:2, 1970.
- [28] Hun, O. & Deu, I. *Tonic, diatonic, & catatonic stage-distress syndromes*. Basel, Karger, 1970.
- [29] Jeanpace, L. & Desmeyeurs, P. Recherches histologiques sur les noyaux de Pesch & de Poissy. *Dijon méd.*, 5:1–73, 1932.
- [30] Karybb, H. & Szÿla, H. Of birds and men : calling strategies and humming responses. *Biol. Gaz. Elec.*, 73:19–73, 1973.
- [31] Kuffler, S.W. Papezian control of aggressive borborygms in Julliard drop-out. *J. physiol. Physiol.*, 2:21–42, 1969.
- [32] Lai, A. & Chou O. Dix-sept recettes faciles au chou à l’ail. I. Avec des tomates. *J. Ass. philharmon. Vet. lang. fr.*, 3:1–99, 1931a.

- [33] Lai, A. & Chou O. Dix-sept recettes faciles au chou à l'ail. II. Avec d'autres tomates. *J. Ass. philharmon. Vet. lang. fr.*, 3:100–1, 1931b.
- [34] Loewenstein, W.R., Lowenfeld, I., Löwen-craft, N., Lowoenshrift Q., & Lewwen, X. Tomatic neuralgia. *J. Neurosurg. Psychiat. Neurol.*, 340:34–49, 1930.
- [35] Mace, I. & Doyne, J. Sur les différents types de réactions tomateuses chez la Cantrice. *Gaz. méd. franco-rus.*, 6:6–11, 1956.
- [36] Malosol, T. Utricular responses during tomato conditioning. *Bul. méd. Aunis & Saintonge*, 43:6–11, 1912.
- [37] Maotz, E. & Toung I. Tomatic innervation of the nucleus ruber. *Proc. Opossum Soc.*, 70:717–727, 1973.
- [38] Marks, C.N.R.S. & Spencer D.G.R.S.T. About the frightening reaction that accompanied first performance of *Il trovatore* at the Metropolitan. *Amer. J. music. deficiency*, 7:3–6, 1899.
- [39] Mason, H.W. & Rangoun, S.W. Paratrigeminaloid musicalgia. In T. Thanos & P. Roxidase, editor, *3rd Conference on the Rimsky-Korsakoff Syndrome*, pages 31–57. Springfield III., C. C. Thomate, 1960.
- [40] McCulloch, W.S., Pitts, W.H. & Levin, R.D. Jr. What's the frog stomach tells to the frog's audience. *Proc. Leap & Frog Ass.*, 64:643–1201, 1964.
- [41] McHullott, E., Mac Haskett, E. & Massinture, E.T.C. Fate of exogenous (^{14}C) scotch, (^{235}U) bloodymary and other triatided compoundds injected in laryngeal and pharyngeal pathway. *Clin. Bull. B.P.R. Soc.*, 89:35–78, 1975.
- [42] Other, S., Colle, E. & Etahl, E. The enzyme enigma revisited. *Amer. J. Allegrol.*, 43:234–567, 1974.
- [43] Otis, J. & Pifre, K. Gaasping in the ascending pathways. In D. Haux & D. Bas, editor, *Hommage à Henri Eiffel*, pages 347–950. Paris, C.N.R.S., 1964.
- [44] Payre, L., & Tairnelle, E. Sur le sursaut tomateux du Baryton léger. *C.r. Assoc. Conc. Lam.*, 45:6–7, 1916.
- [45] Pericoloso, O., & Sporgersi, I. Sull'effeti tometestiche e corticali della stimolazione di leguminose nella Diva. *Arch. physiol. Schola Cantor*, 37:1805–1972, 1973.
- [46] Pesch, U. Experimentelle Beiträge über anterior reticularis Kerne beim Minnesänger. *Von Bulow's Arch.f.d.ges. Musikol.*, 1:1–658, 1876.
- [47] Poissy, N. de. Atrophie congénitale des Noyaux de Pesch. *Bibl. clin. Homeoprat. Lugdun*, 65:22–31, 1880.
- [48] Pompeiano, O., Vesuviana, A., Strombolino, H. & Lipari, G. Volcaniche effetti della formazione reticolare nella funiculi funicula. *C.r. Ass. ital. Alat. bel Cant.*, 37:5–32, 1971.
- [49] Remmers, J.E. & Gauthier, H. Neural and mechanical mechanisms of feline purring. *Resp. Physiol.*, 16:351–361, 1972.
- [50] Roux, C.F. & Combaluzier, H.U. Le syndrome de Charlotte. *Weimar Ztschr. musikol. pomol.*, 7:1–14, 1932.
- [51] Sinon, E., Evero I., & Ben Trovato, A. Psychopathological description of *La Furia di Caruso* (in italian). *Folia clin. otorhinolaryngol., Fouv. Tataouine*, 6:362–363, 1948 (Quoted by Hun & Deu, 1960).
- [52] Sornette, U. & Billeveyzé, H. Les stomatites tomateuses. *Arch municip. Météorolog. lyr. Déontol. music.*, 264:14–18, 1925.
- [53] Strogonoff, H. Iii. pineal activation and yelling reaction. *Show Busin. Gaz.*, 3:273–308, 1960.
- [54] Strum, U. & Drang, F. *Musikalische Katastrophe*. Berlin, W. de Gruyter, 1973.
- [55] Szentagothai, J. The substantia nigra as striatal machine. *Bull. Ass. niger. Neurophysiol. clin. exp., Niamey*, 23:25–40, 1972.
- [56] Tarama, K. *Acid-base balance*. pHD, San Francisco, 1957.
- [57] Tebaldi, R. La Callas revisited. *Metropolitan J. endocrin. Therap.*, 6:37–73, 1953.
- [58] Timeo, W., Danaos, I & Dona-Ferentes, H.E.W. Brain cutting and cooking. *Arch. metaphys. endogen. Gastrom.*, 56:98–105, 1973.

- [59] Unsofort, H. & Tchetera, K.G.B. Shout and Yell. *Yale J. Med. J.*, 9:9–19, 1950.
- [60] Van der Deder, J. Von. The yelling pathway. *San Diego J. exp. Teratol.*, 50, Suppl. 24:1–28, 1950.
- [61] Vincent, J., Milâne, J., Danzunpré J.J. & Sanvaing-Danlhotte, J.J.J. Le réflexe hydro-musical. *Gaz. méd. Faidh. Chalign. & d.s.Fil.*, 1976 (in the press).
- [62] Von Aitick, A. Ueber geminal-niebelungenischen schmerz. *Ztschr. exp. pathol. Tomatol.*, 4:4a–64P, 1940.
- [63] Wait, H. & See, C. Ballistic requirements in tomato throwing and splatching. *Nasa Rept. N°68/675/002/F4*, pages 1–472, 1972.
- [64] Wimbledon, A.F.G.H. On the statistical matching of neuronal and other data. *J. dynam. Stat.*, 5:1–28, 1974.
- [65] Zakouski, B.G.H. Investigations d'avant-garde sur les voies fluviales artificielles à moitié rondes dans le hall d'entrée. (traduit du russe). *Exp. J. sechenov. Pflügerol.*, 3:17–34, 1954.
- [66] Zeeg, O. & Puss, I.K. On the fanatic demonstrations of music lovers. *J. behav. developm. Psychobiol.*, 31:1–13, 1931.
- [67] Zubrowska, A. Oculo-tomatic dyskenia. A preliminary report. *J. neuro-neurol. Neurol.*, 1:107, 1958.
- [68] Zyszytrakyczywsz-Sekrąwszkiwcz , I. The Monte Carlo theorem as a use in locating brain and other sites. *J. math. Vivisec.*, 27:134–143, 1974.